

M12x30

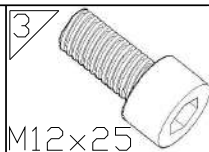

M12x25

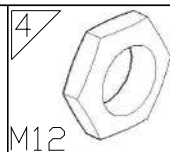

M12



M6x45

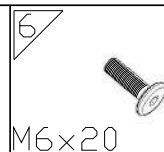

M6x20

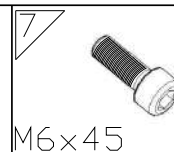

M6x45

  
**GRAVITY DESK**



Ramę biurka należy ustawić w docelowym miejscu, ponieważ po zmontowaniu nie będzie można zmienić jej położenia. Wymagana wytrzymałość podłogi to 600 kg/ punkt.

Desk frame should be put at the desired place, as it will be impossible to move it after assembly. Required floor strength is 600 kg/ spot.

Gestell des Schreibtischs soll am Zielort platziert werden, da es nach der Montage nicht umgestellt werden kann. Erforderliche Bodenfestigkeit ist 600 kg/ Punkt.

Il est nécessaire de poser le cadre du bureau dans le lieu de destination finale car une fois monté, il sera impossible de changer sa position. La résistance exigée du plancher est de 600 kg/point.

**.mdd**

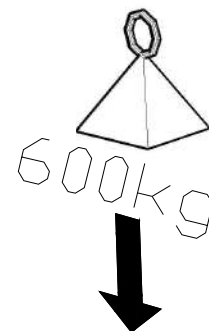
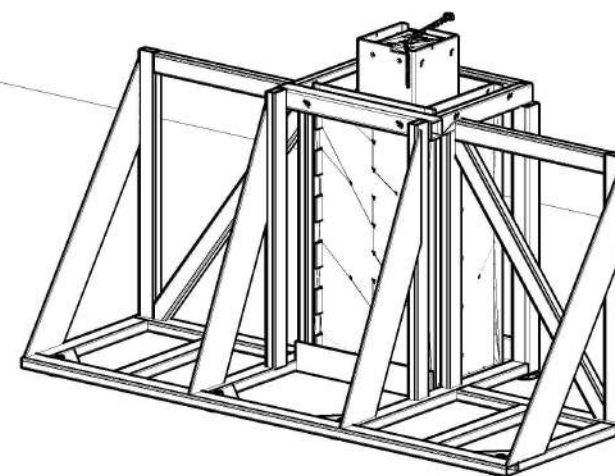
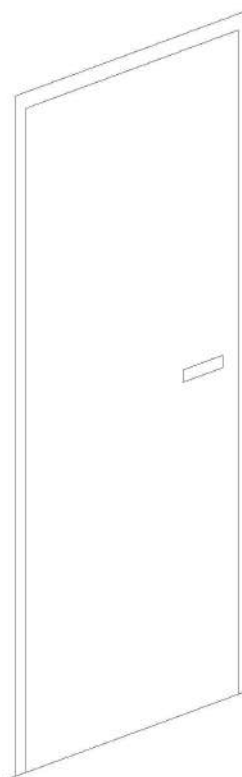

B

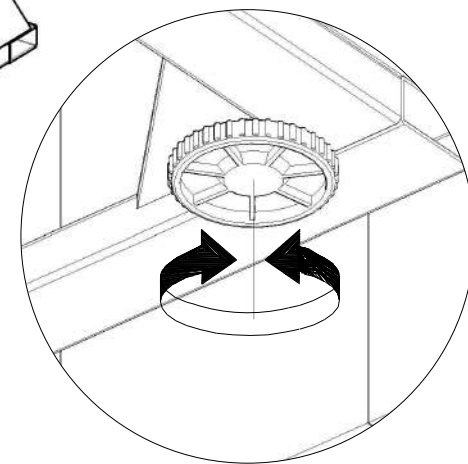
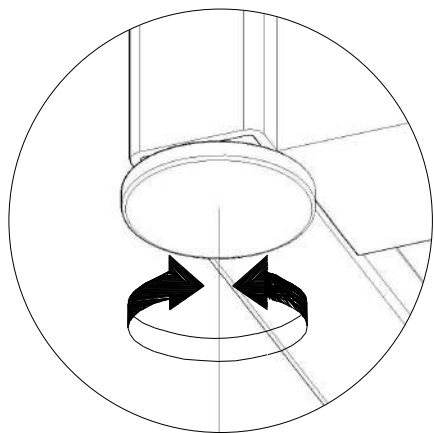
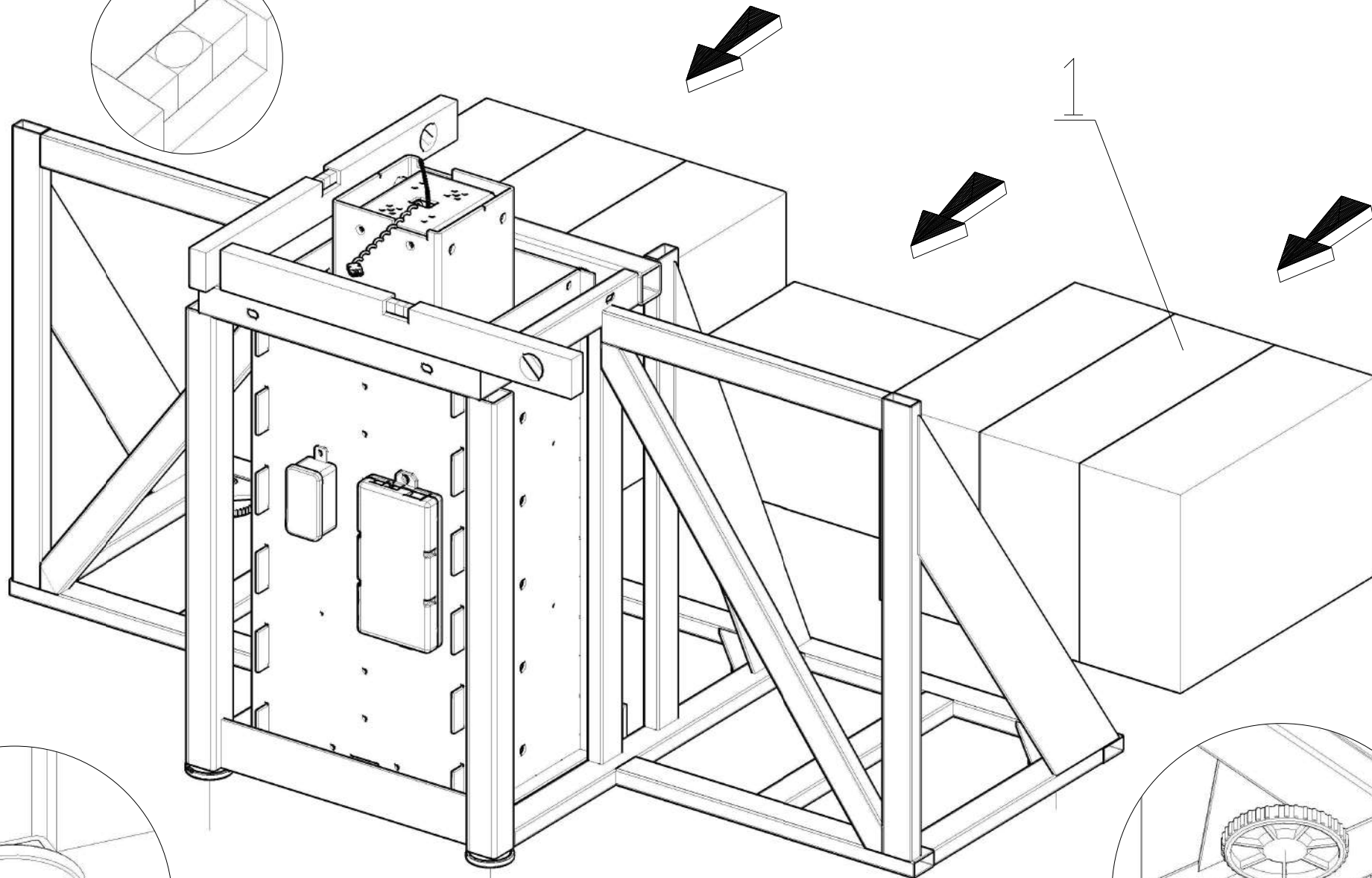
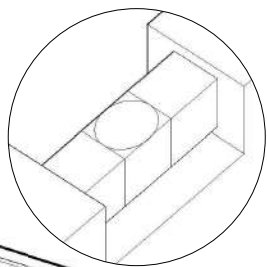

C

1

3

1

2

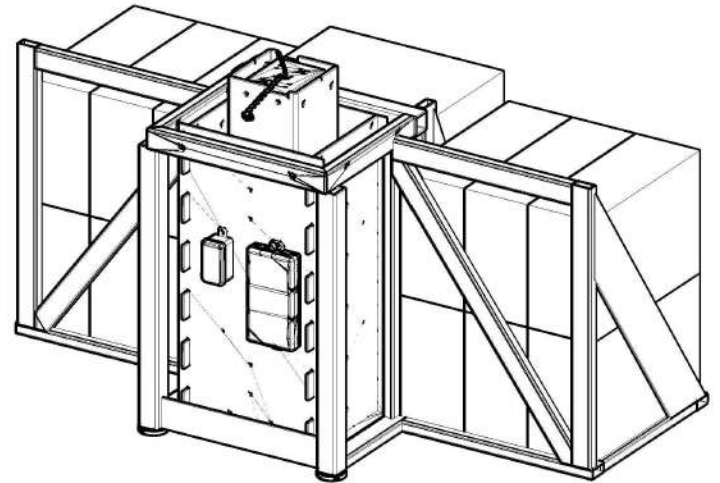
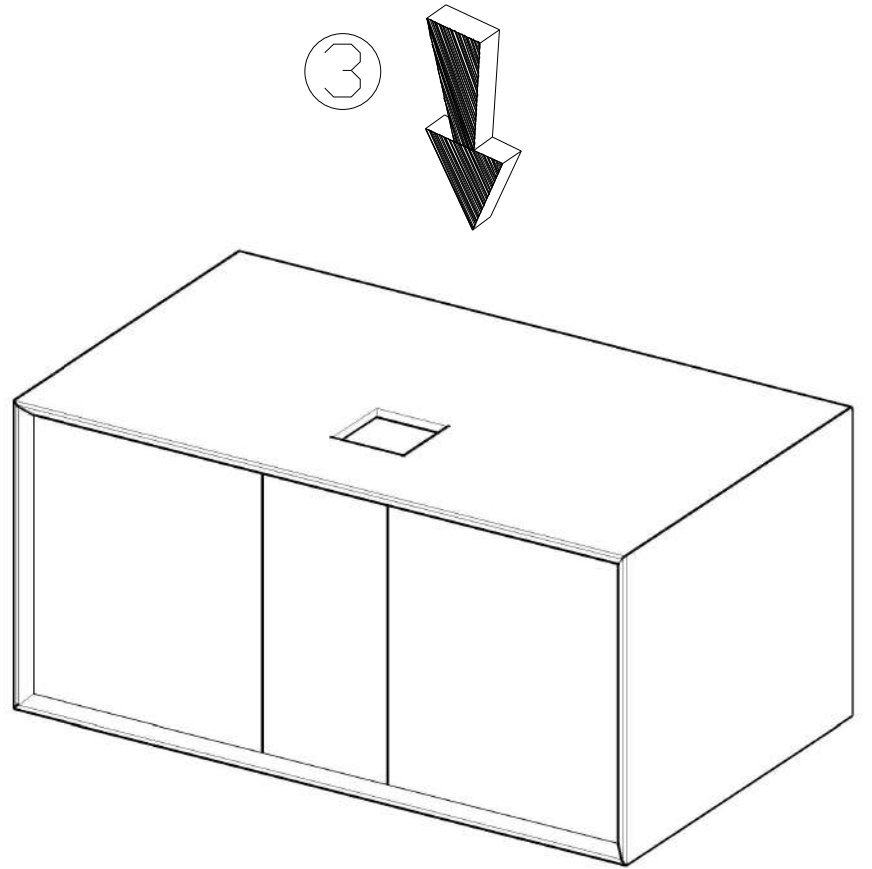
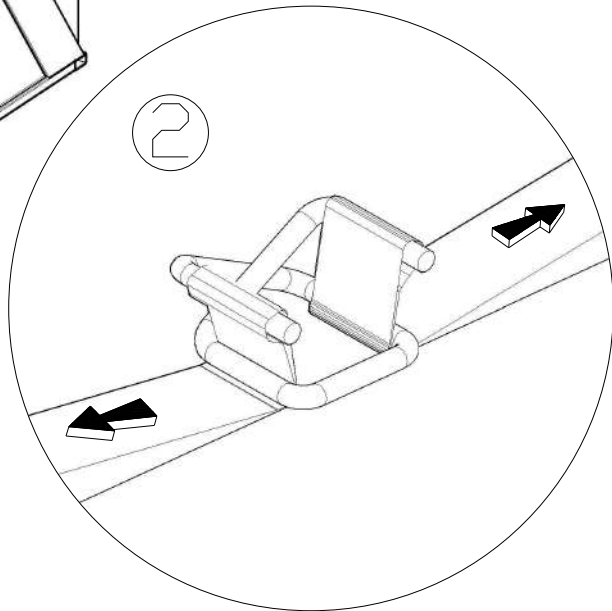
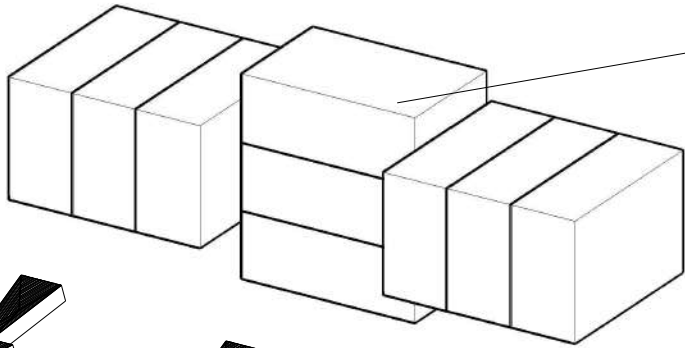
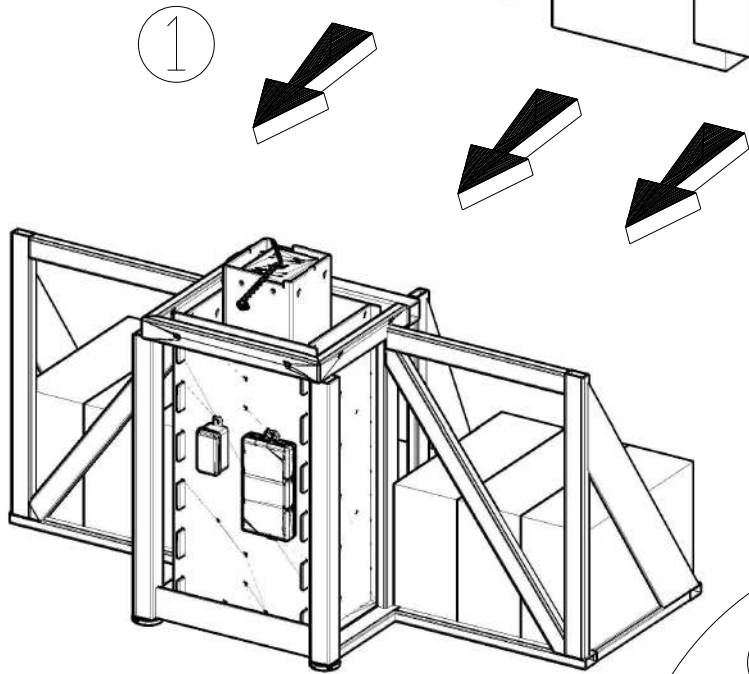

D

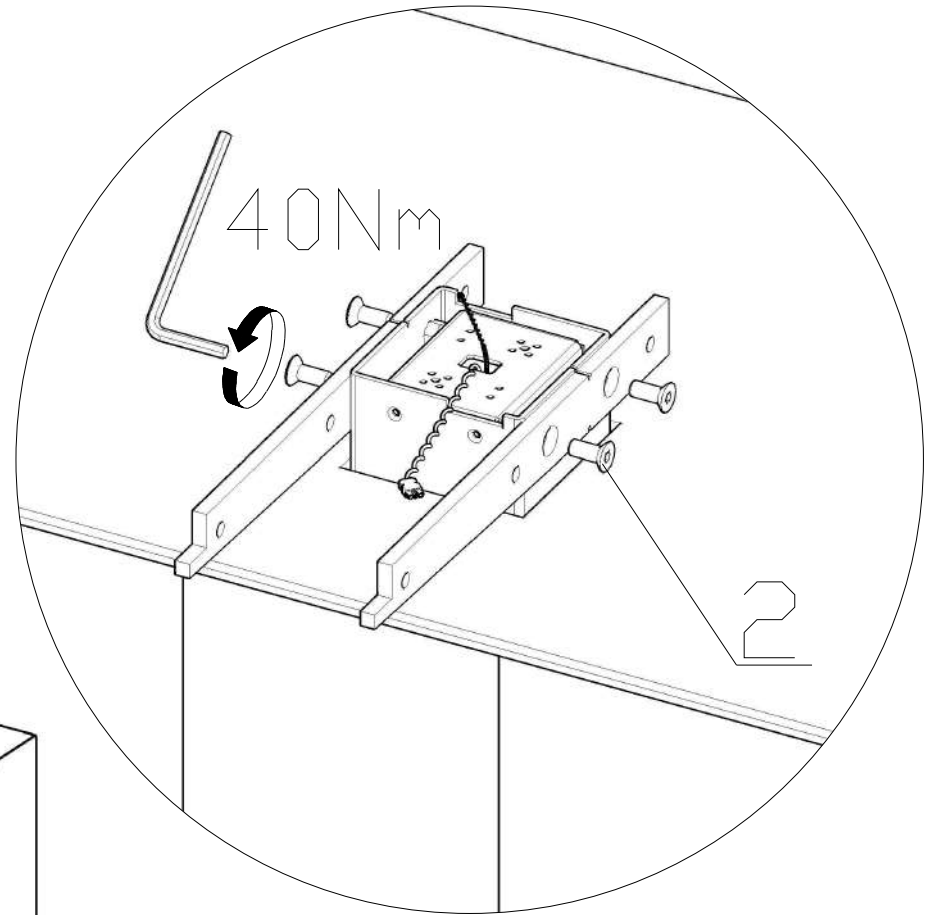
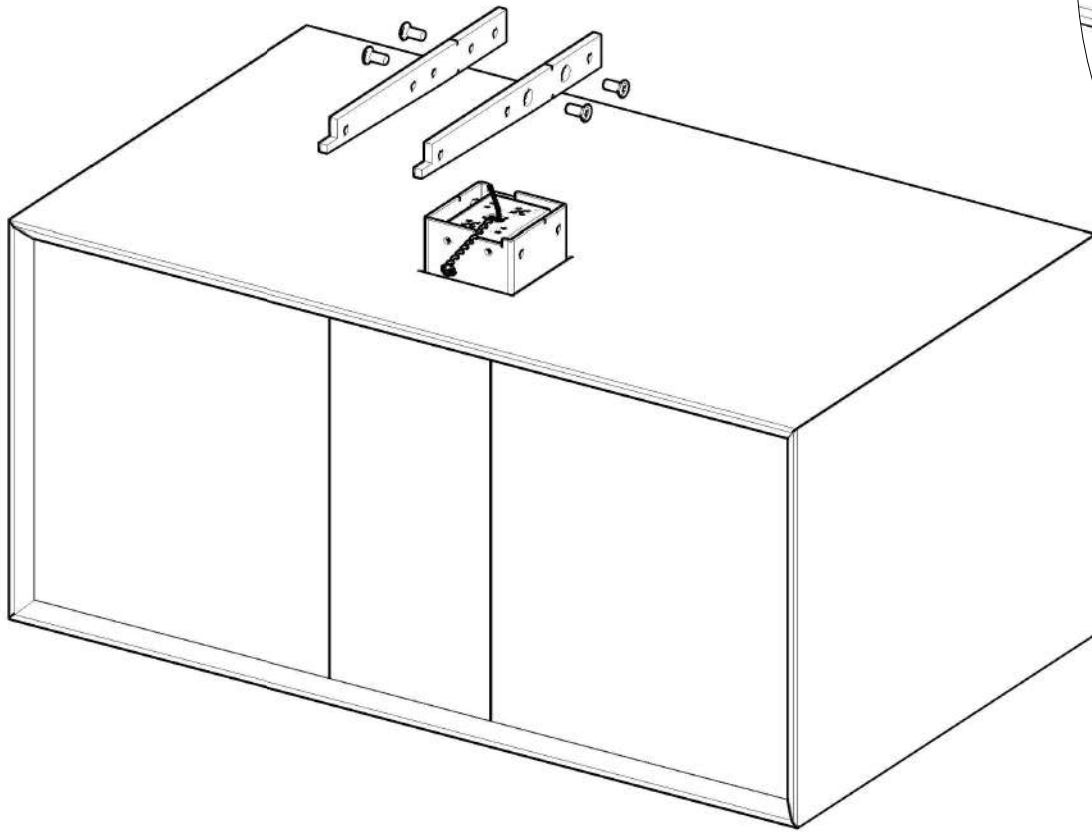

E

①

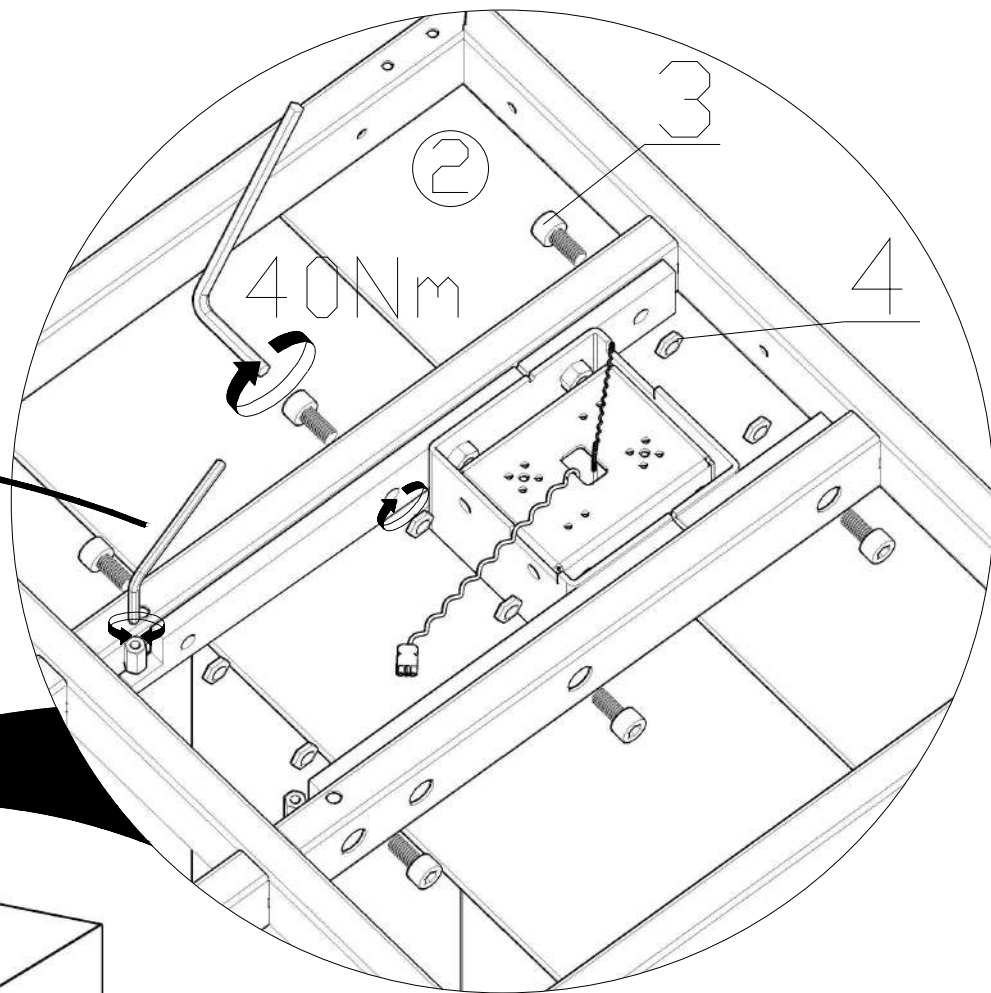
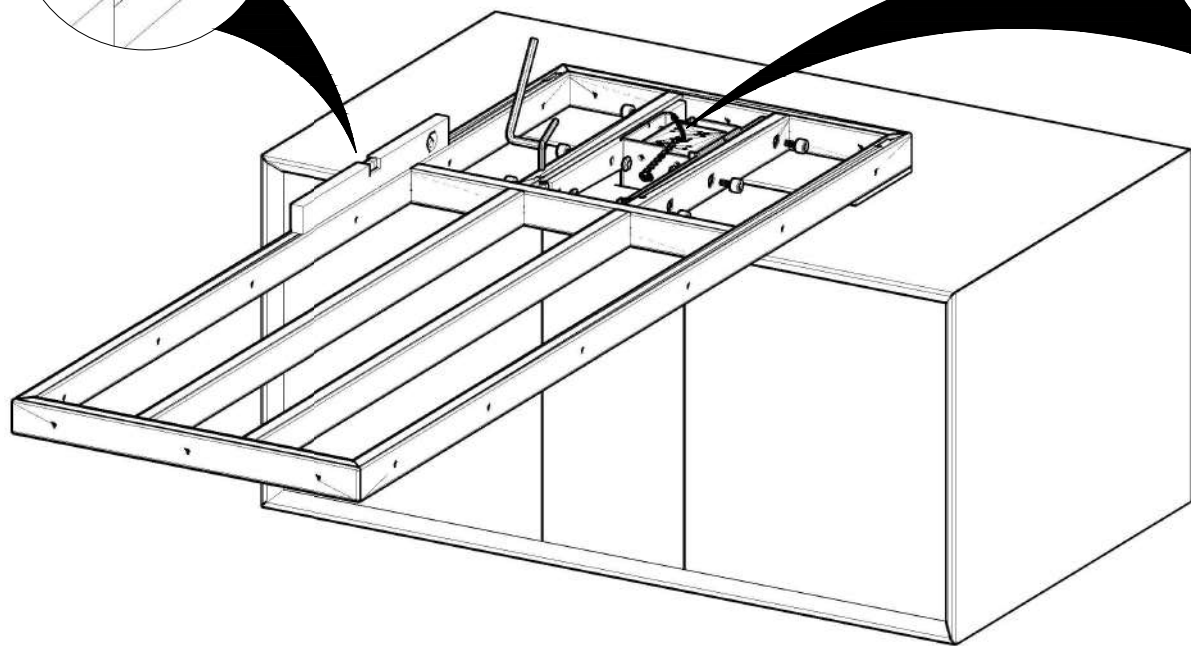
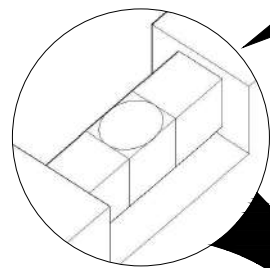

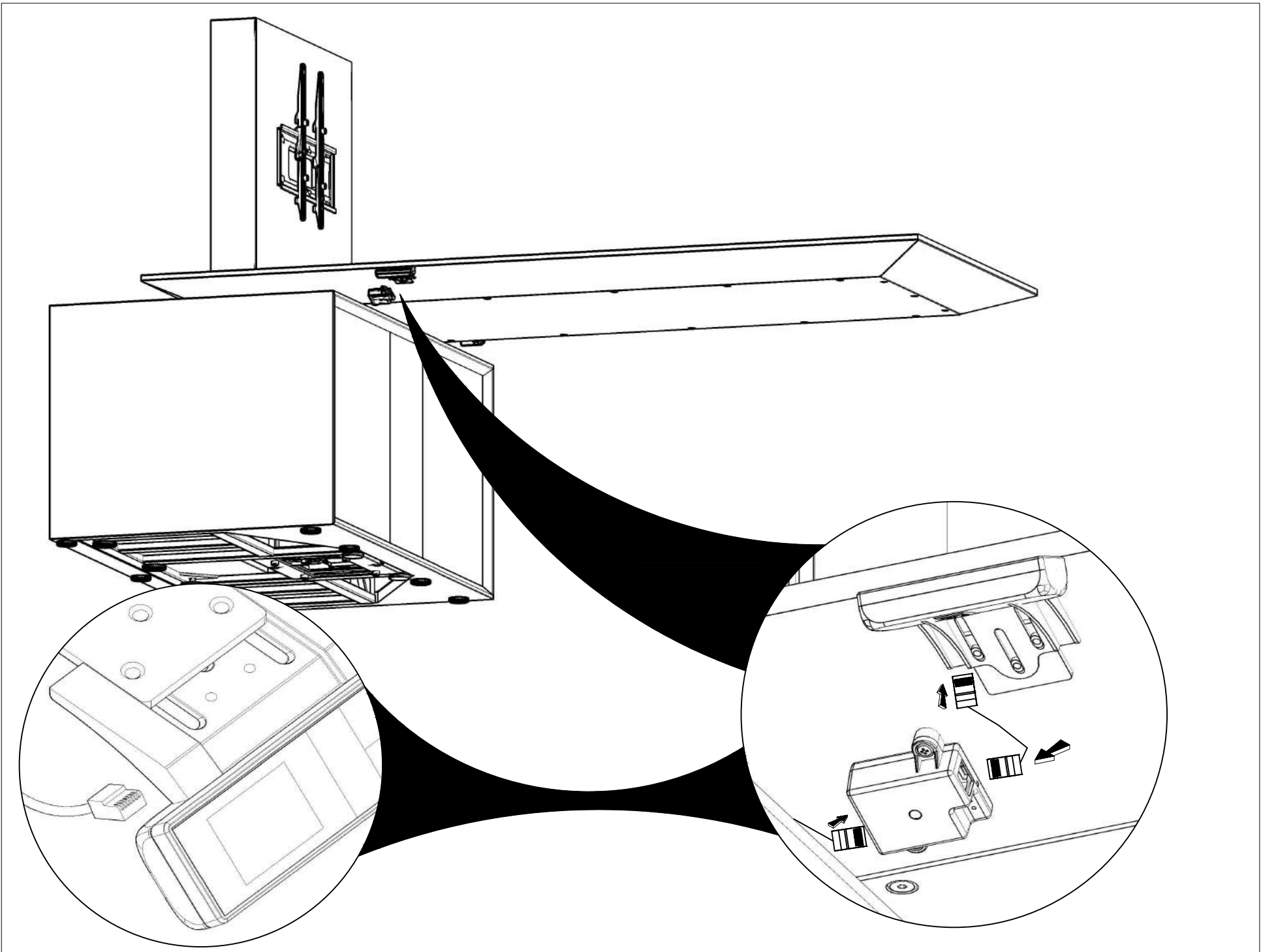

F

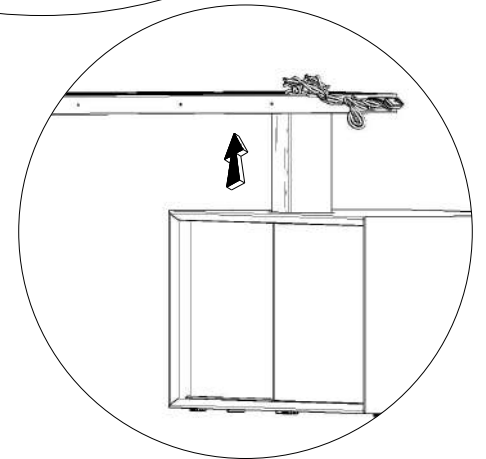
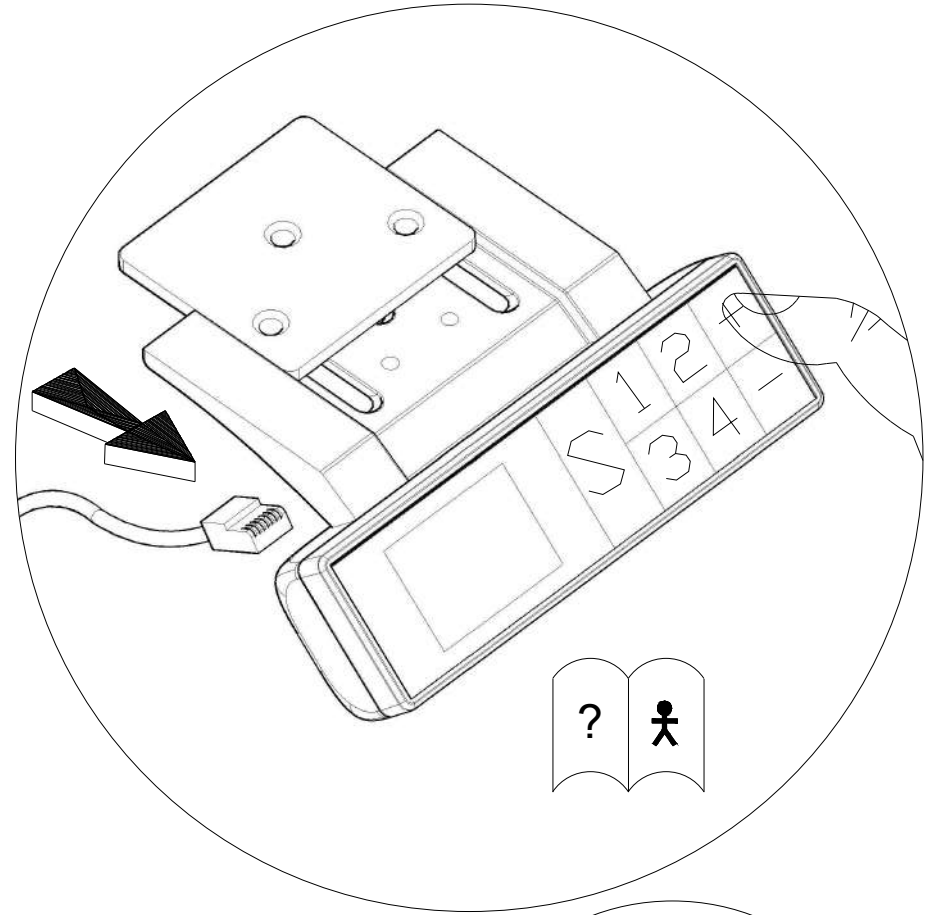
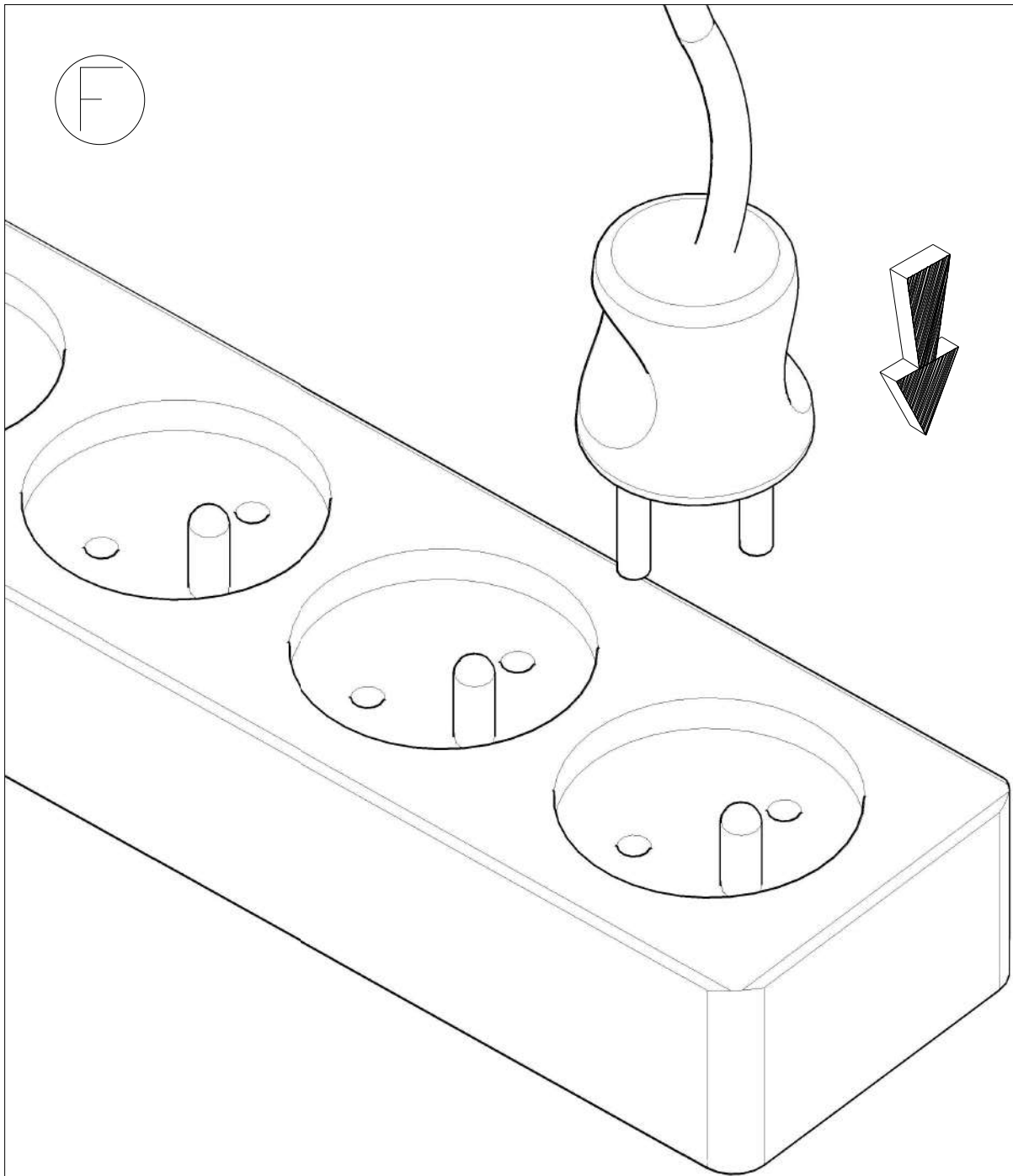

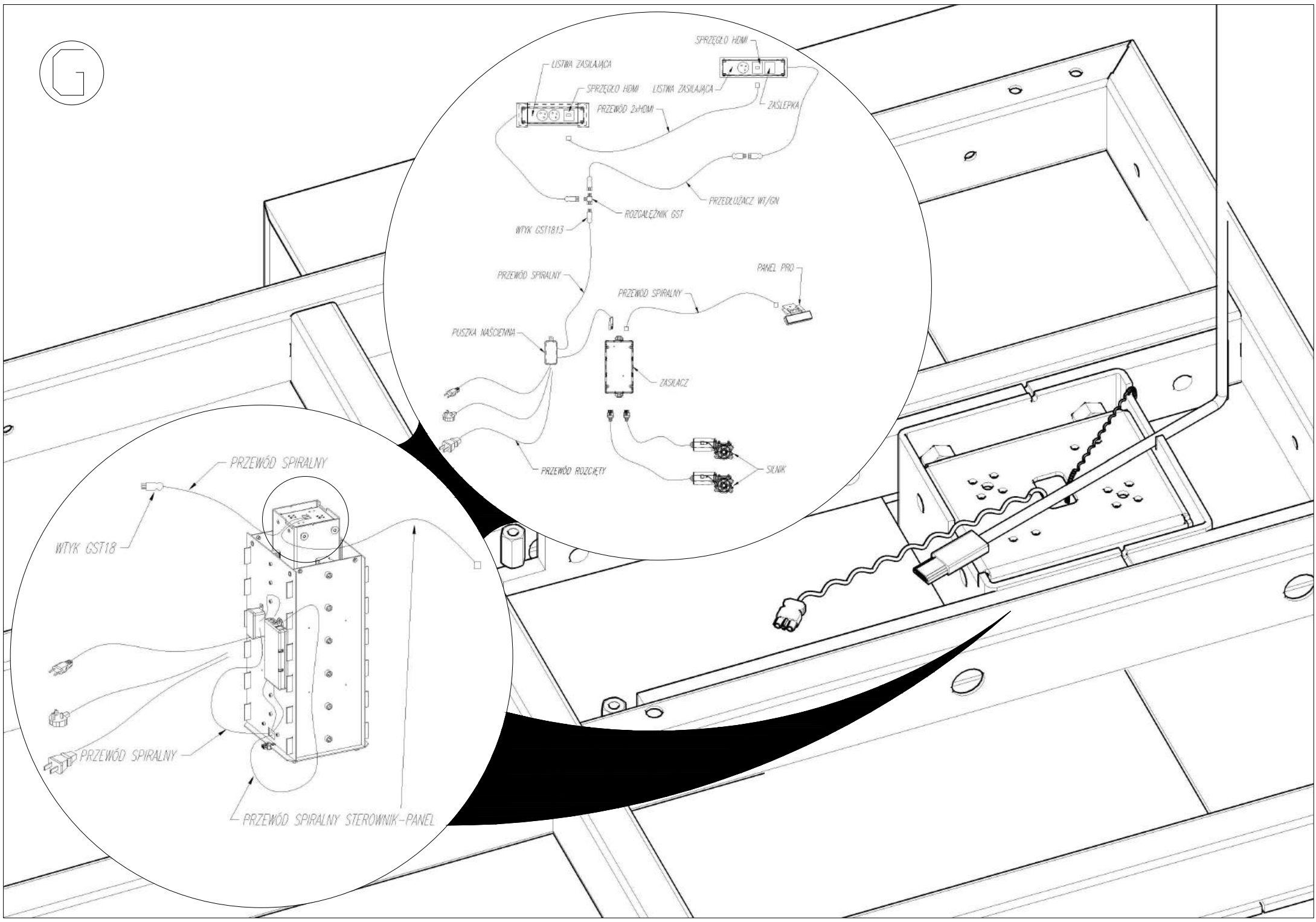
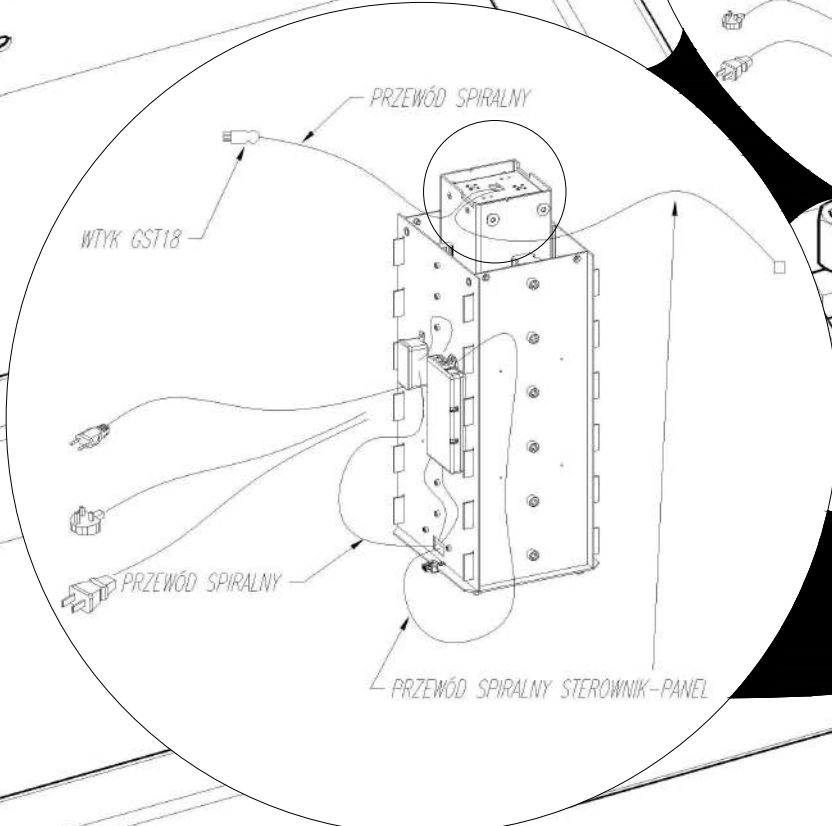
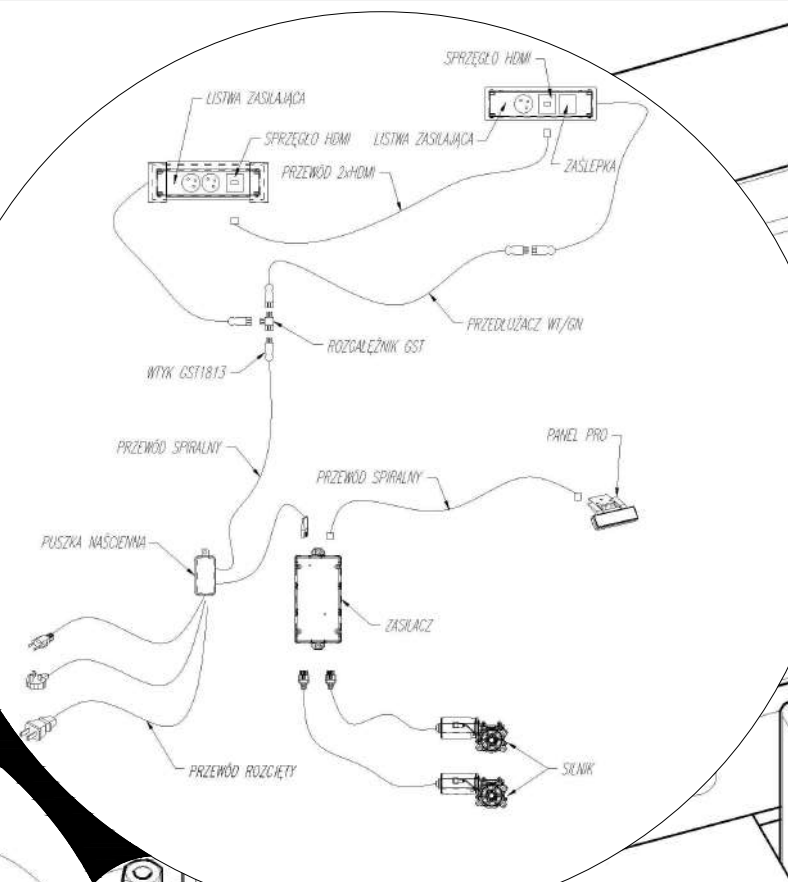

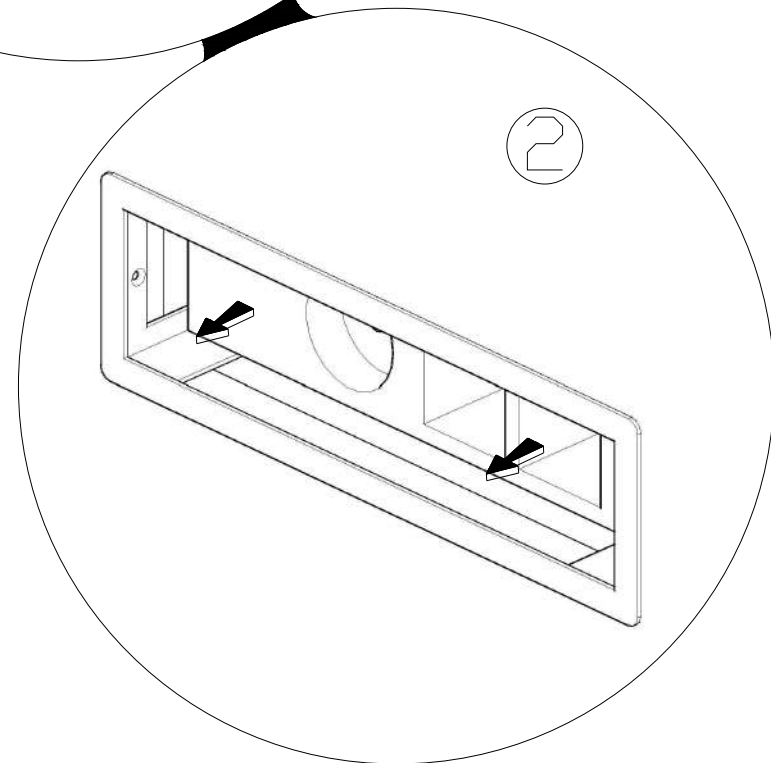
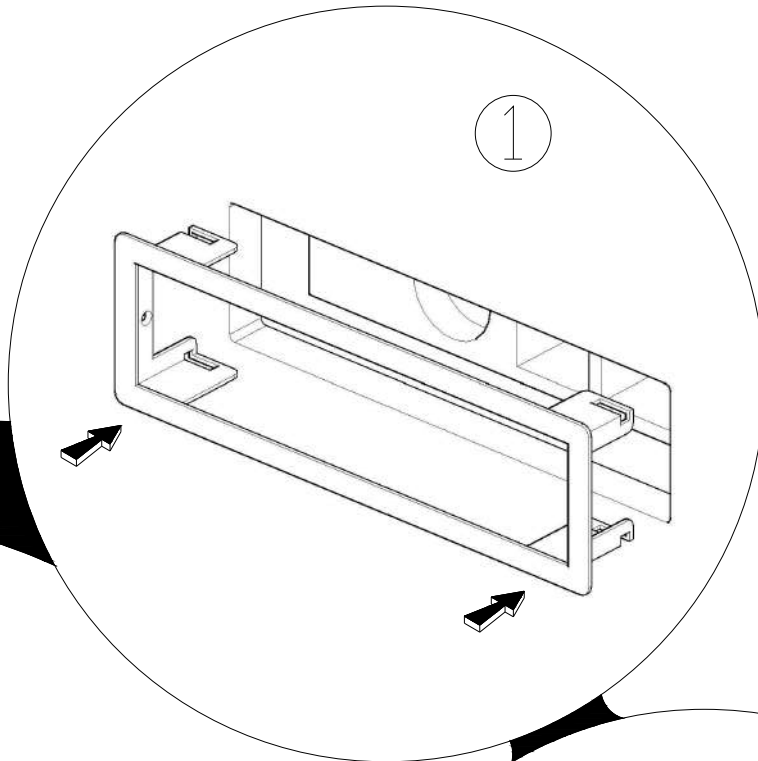
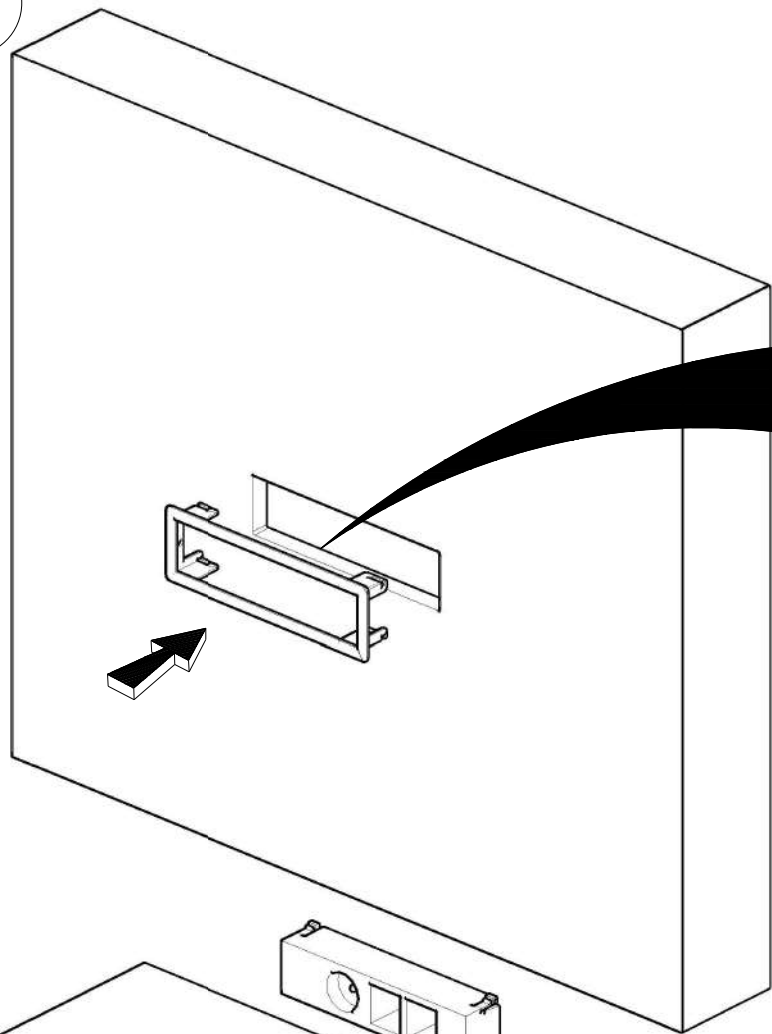

I

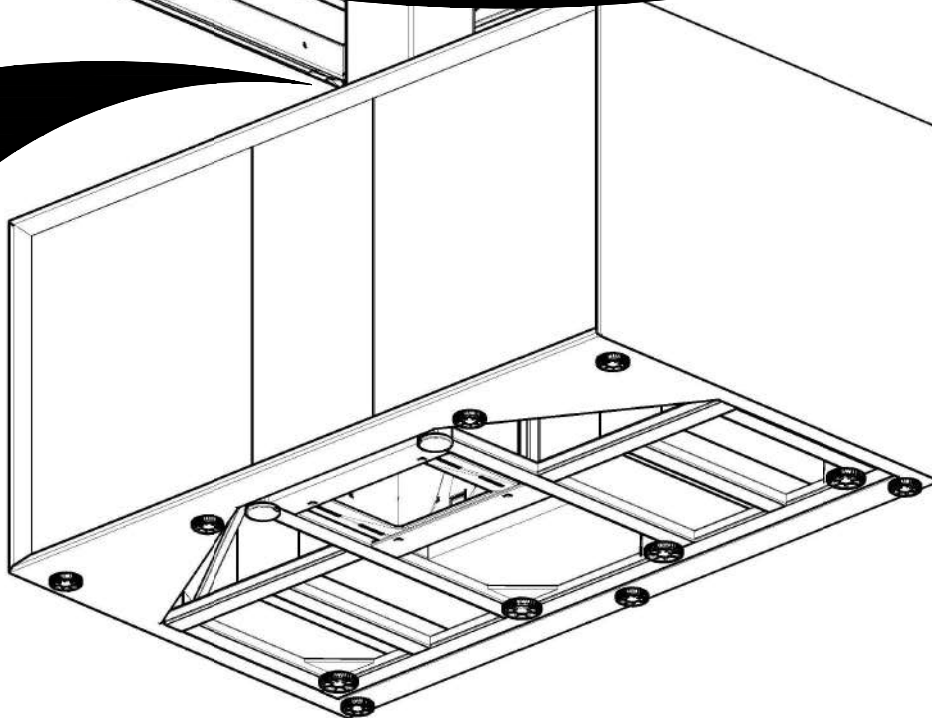
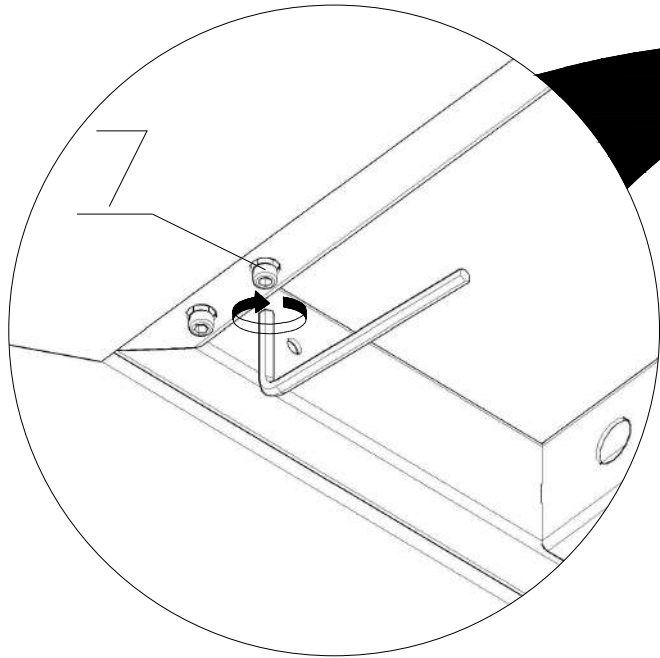
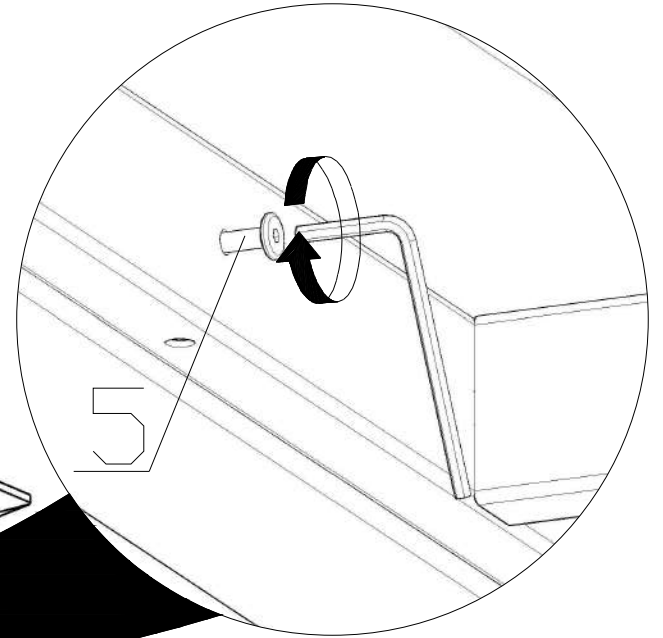
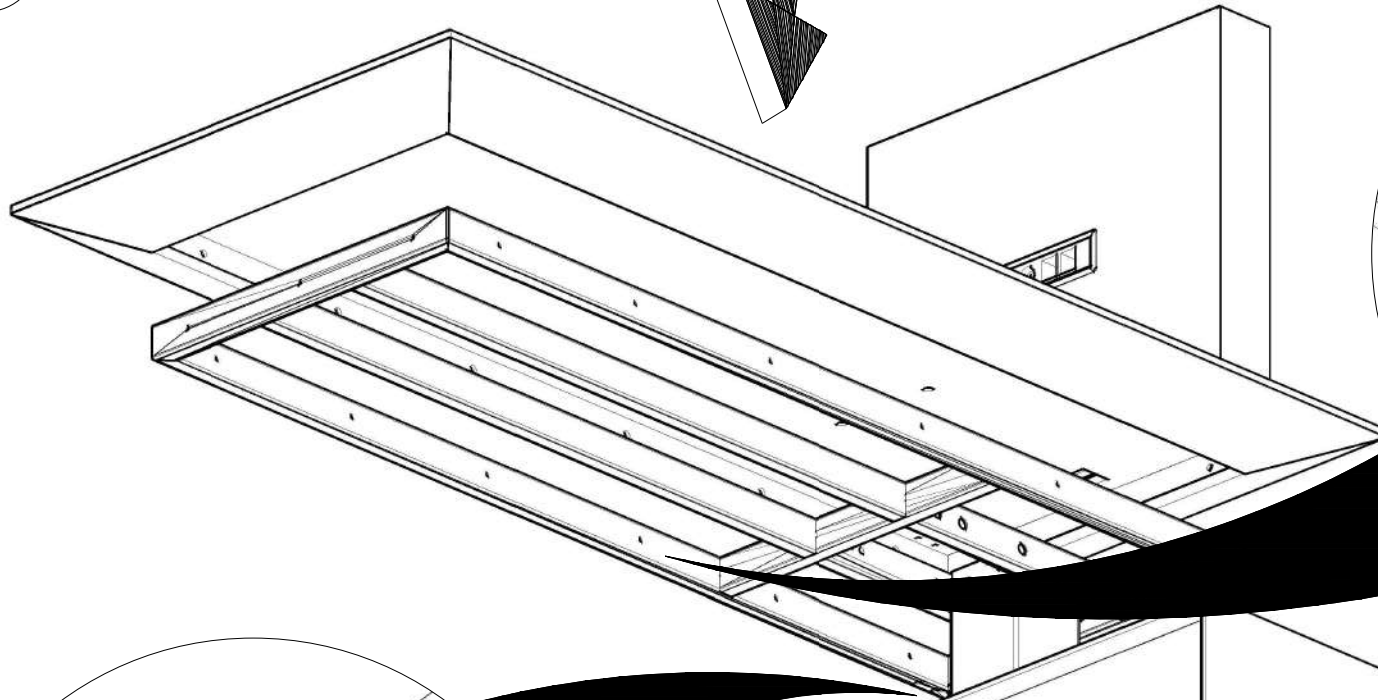
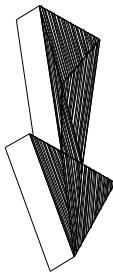

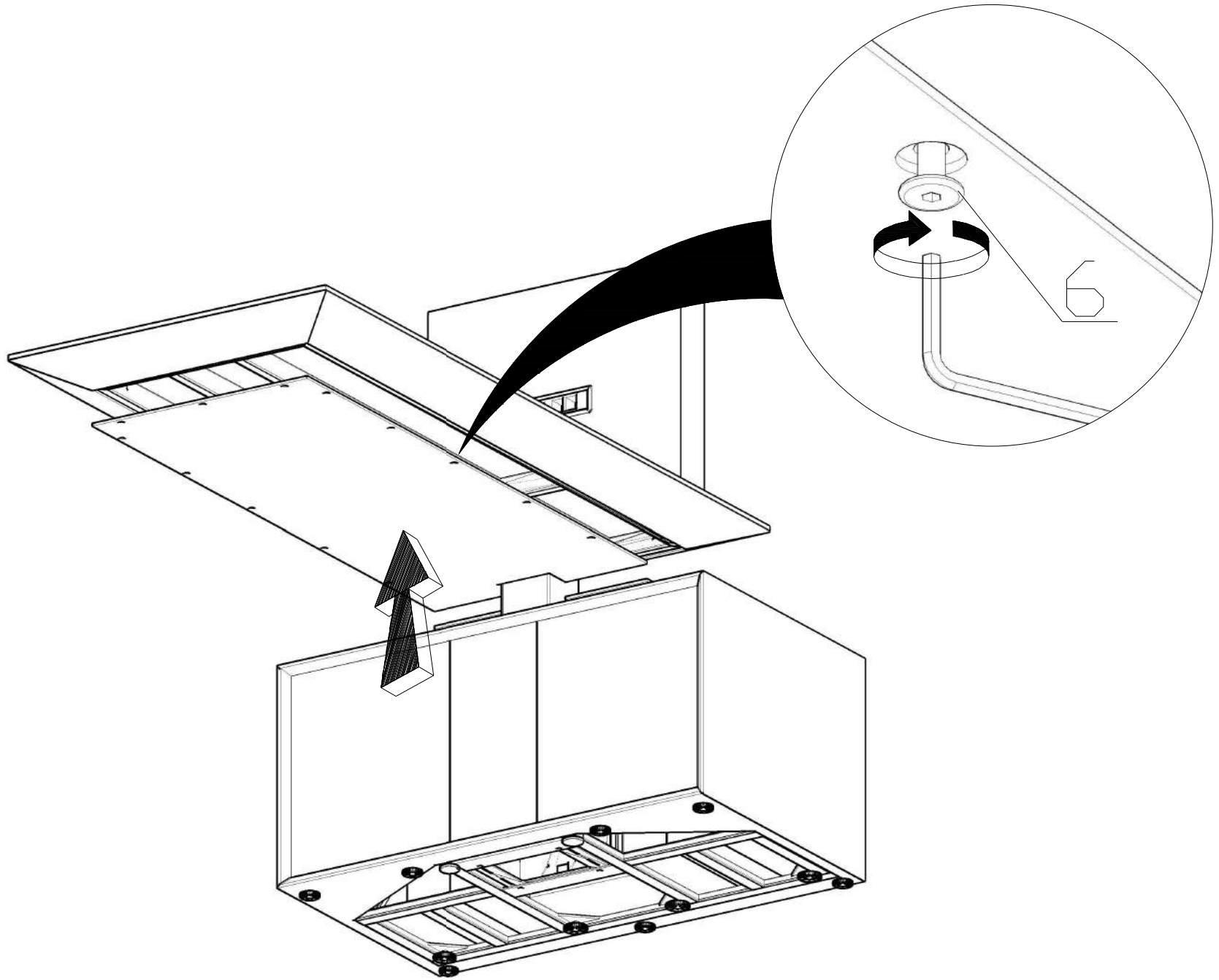
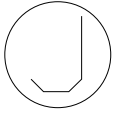

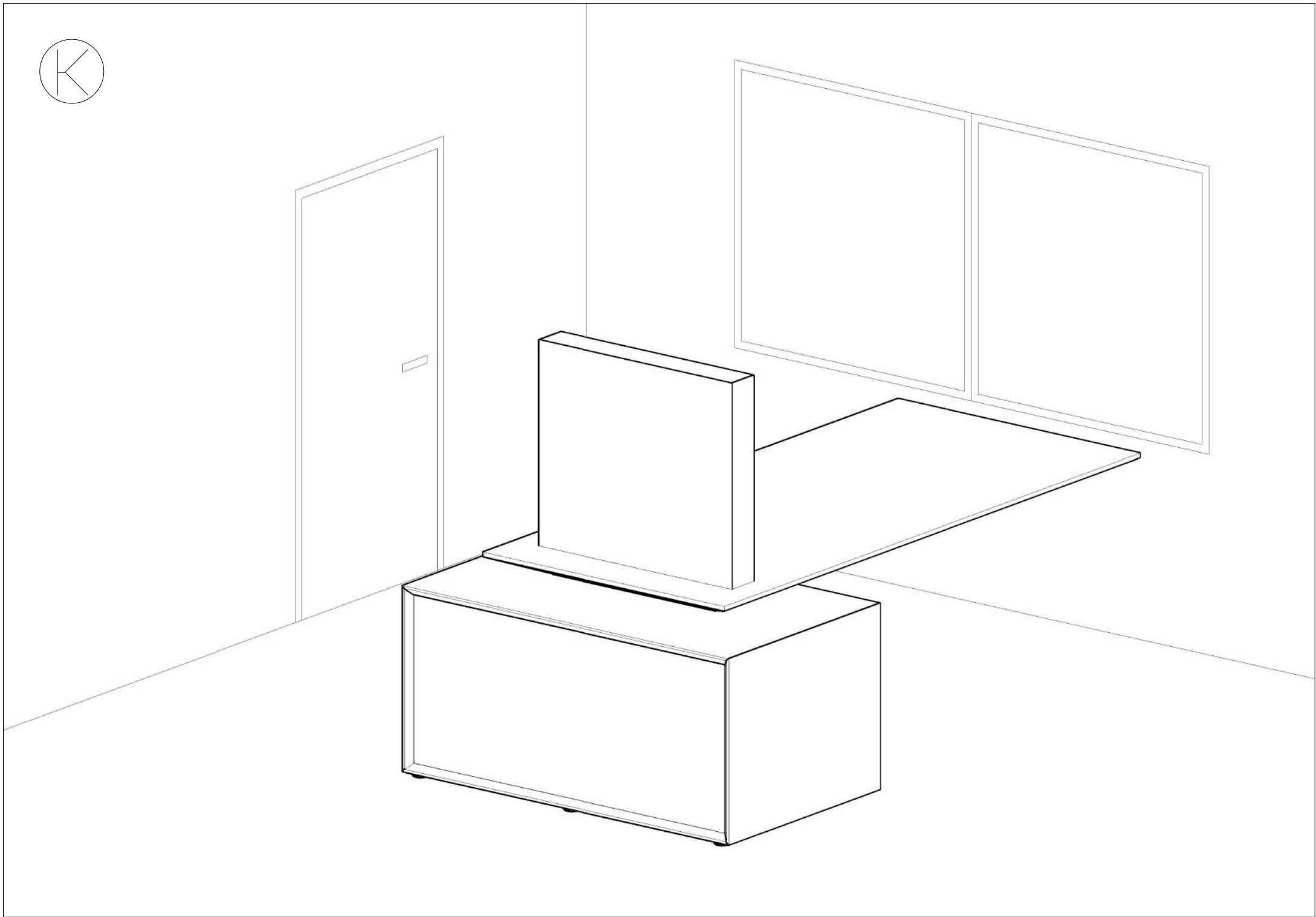
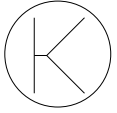

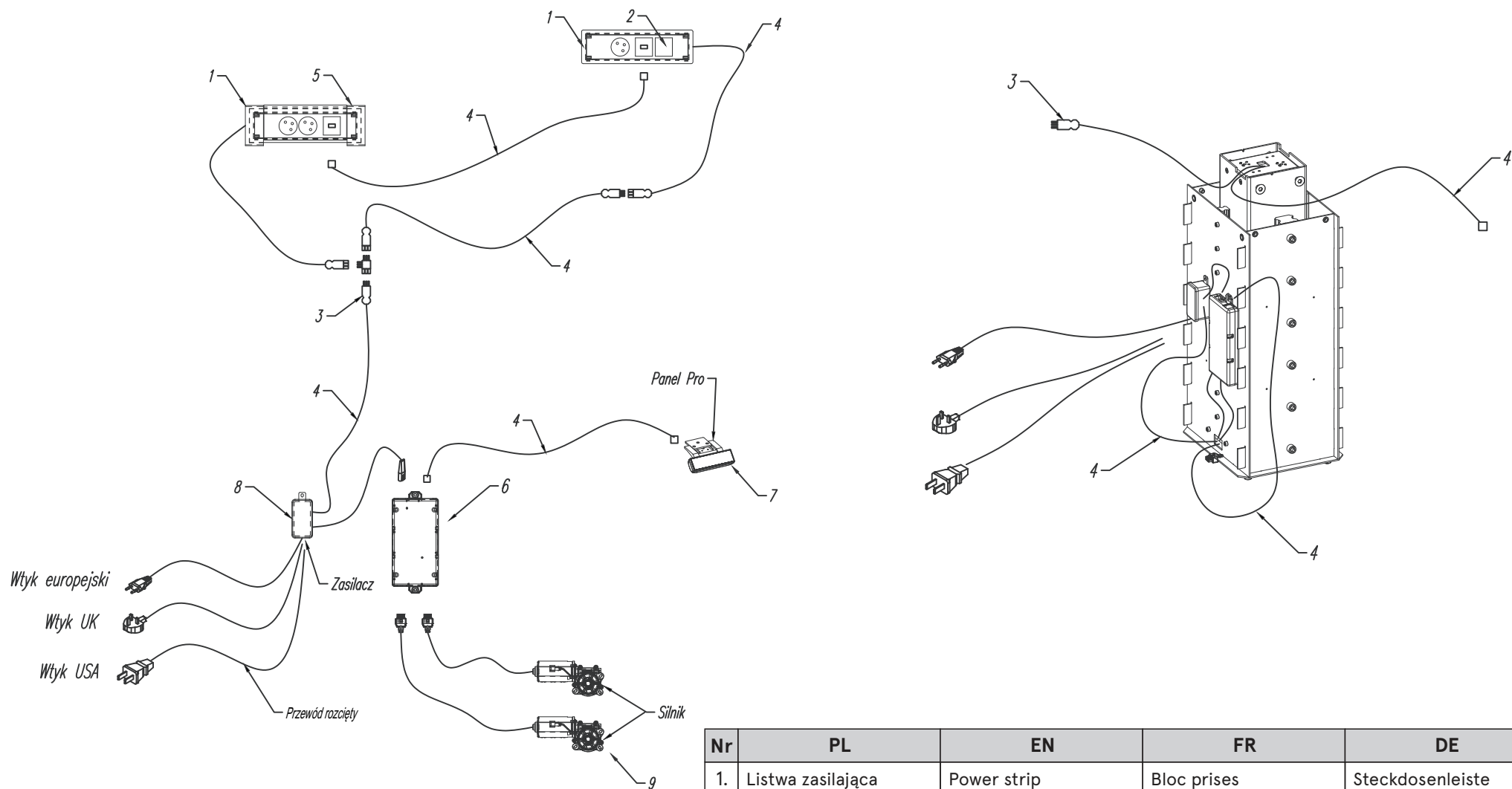





Nr	PL	EN	FR	DE
1.	Listwa zasilająca	Power strip	Bloc prises	Steckdosenleiste
2.	Zaślepka	Plug	Cache-trou	Abdeckkappe
3.	Wtyk GTS1813	GTS1813 pin	Connecteur GTS1813	Stecker GTS1813
4.	Przewód spiralny	Spiral wire	Cordon spiralé	Spiralkabel
5.	Puszka naścienna	Wall-mounted box	Boite murale	Verbindungsdose
6.	Sterownik-panel	Controller-panel	Contrôleur-le panneau	Steuerungspanel
7.	Panel PRO	PRO panel	Panel PRO	Steuerungspanel PRO
8.	Zasilacz	Power supply unit	Alimentation électrique	Netzteil
9.	Silnik	Motor	Moteur	Motor

## Drogi Kliencie!

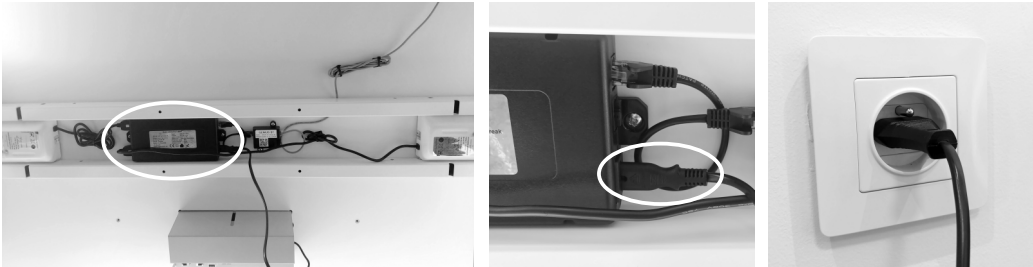
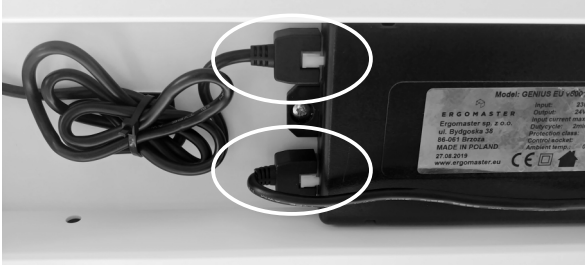
Jeśli zauważyłeś, że Twoje biurko nie funkcjonuje prawidłowo, prosimy o sprawdzenie poniższych rozwiązań:

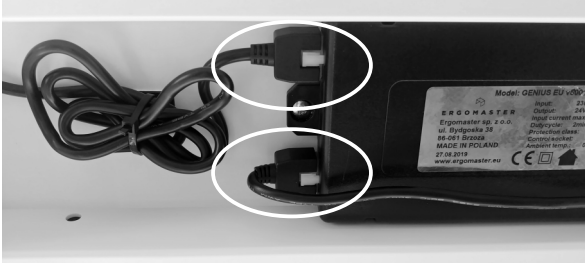
L.p.	SYTUACJA	MOŻLIWE ROZWIĄZANIE
1	Biurko nie reaguje na przyciski	Sprawdź połączenie kabla zasilającego do sprawnej sieci oraz do sterownika.
2	Nie działa przycisk 	Przytrzymaj <b>nieprzerwanie</b> przycisk  do momentu obniżenia blatu do najniższej pozycji - nastąpi kalibracja nóg i zostanie przywrócona możliwość regulacji blatu w obu kierunkach.
3	Jedna noga przestała działać lub ma inną wysokość	<p>Należy ponownie przeprowadzić proces kalibracji. W tym celu:</p> <p>a) najpierw upewnij się że sterownik jest podłączony do zasilania</p>  <p>b) odłącz wtyczki kabli nóg od sterownika</p>  <p>c) odłącz kabel zasilający od sieci na <b>10 sekund</b></p> <p>d) podłącz ponownie kabel zasilający do sieci sprawdź jego podłączenie do sterownika</p>  <p>e) podłącz ponownie wtyczki kabli nóg od sterownika aż usłyszysz „klik” zaczepek wtyczki</p>  <p>f) skalibruj nogi zgodnie z <b>punktem 2.</b></p>

L.p.	SYTUACJA	MOŻLIWE ROZWIĄZANIE
4	<p>Po naciśnięciu przycisku „+” lub „-” biurko zaczyna ruch, jednak samoczynnie zatrzymuje się i cofa o 4cm, na wyświetlaczu pojawia się komunikat LOWER/UPPER ANTICOLLISION</p>	<ol style="list-style-type: none"> <li>1. Nastąpiło uruchomienie systemu antykolizyjnego - w czasie ruchu blat zetknął się z przeszkodą – USUŃ PRZESZKODĘ</li> <li>2. Nastąpiło uruchomienie systemu antykolizyjnego pomimo, że blat nie zetknął się z żadną przeszkodą. UPEWNIJ SIĘ, ŻE: <ol style="list-style-type: none"> <li>a) biurko przebywało w temperaturze pokojowej przez co najmniej 1 godzinę</li> <li>b) całe biurko jest solidnie skręcone bez luzów na śrubach</li> <li>c) sterownik jest dobrze przymocowany - nie rusza się</li> <li>d) kabel zasilający jest przymocowany uchwytem do konstrukcji biurka, zgodnie z instrukcją, tak aby jego ciągnięcie nie powodowało ruchów sterownika</li> <li>e) biurko jest wypoziomowane i nie jest przeciążone</li> <li>f) w biurkach typu bench – Upewnij się, że opaska belki łączącej nogi, nie jest skręcona zbyt mocno (zbyt mocne skręcenie może powodować deformację nog, uniemożliwiając płynny ruch kolumn wewnętrznych)</li> </ol> </li> </ol> <div style="text-align: center;">  </div> <p>g) przeprowadź na koniec kalibrację wg punktu 3.</p>
5	<p>Po wielokrotnej zmianie pozycji blatu (w krótkim czasie) biurko przestało działać</p>	<p>Sterownik ma zabezpieczenie przed przegrzaniem, które nie pozwala na dalszą pracę. Oczekaj 18 min na schłodzenie sterownika i silników. W biurkach z panelem sterującym Pro – czas chłodzenia widoczny jest na wyświetlaczu.</p>

Jeżeli żadne z przedstawionych rozwiązań nie przyniosło oczekiwanego rezultatu, należy skontaktować się z dystrybutorem przesyłając krótki film pokazujący zachowanie/ brak reakcji biurka na przyciskanie klawiszy „+” i „-”

W przypadku braku możliwości wykonania filmu należy wypełnić poniższe zgłoszenie z opisem sytuacji:

Sprawdzone zostały sugerowane rozwiązania problemu wg fabrycznej instrukcji, ale biurko nadal nie działa prawidłowo.

Akcja:	Opis zachowania biurka
Naciskanie przycisku „+”	...
Naciskanie przycisku „-”	...

### Uproszczona procedura kalibracji

Sprawdź czy sterownik jest podłączony do zasilania a panel sterujący i nogi podłączone do sterownika.

Następnie:

Panel sterujący STANDARD:



1. Wciśnij jednocześnie i trzymaj **nieprzerwanie** przez 4 sekundy oba przyciski



2. Po tej czynności klawisz **+** pozostaje nieaktywny
3. Następnie przyciskiem **-** opuść biurko w dół do najniższej pozycji obu kolumn
4. Po tej czynności klawisz **+** będzie aktywny





Panel sterujący PRO:



1. Wciśnij jednocześnie i i trzymaj **nieprzerwanie** przez 4 sekundy wszystkie 3 przyciski **S** **+** **-**
2. Po tej czynności klawisz **+** pozostaje nieaktywny
3. Następnie przyciskiem **-** opuść biurko w dół do najniższej pozycji obu kolumn
4. Po tej czynności klawisz **+** będzie aktywny

## Dear Customer!

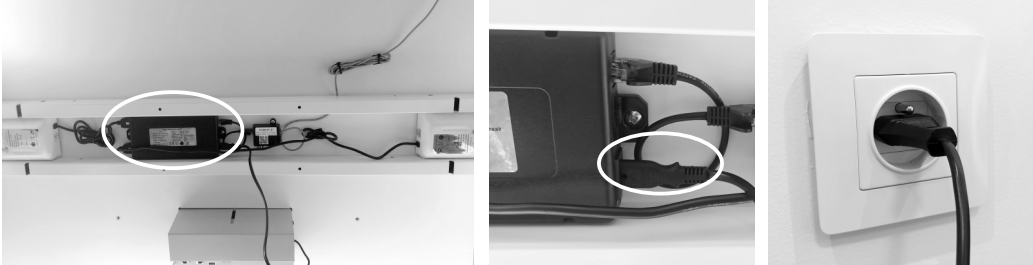
If you noticed that your desk is not working properly, please check the following solutions:

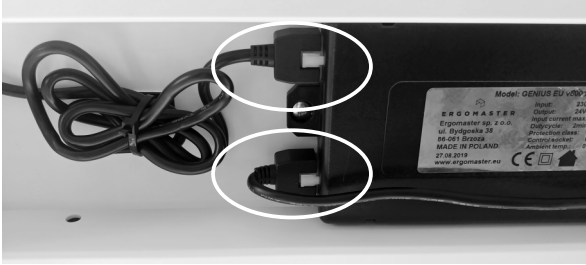
L.p.	ISSUE	POSSIBLE SOLUTION
1	The desk does not respond while pressing the buttons	Check the power cable connection. Check if it is connected to a working network and the controller.
2	<p>The  button does not work</p>	Hold the  button continuously until the worktop is lowered to the lowest position - legs will be calibrated and worktop adjustment will be restored in both directions.
3	One of the legs has stopped working or has a different height	<p>The calibration process must be performed again. In order to do that:</p> <p>a) make sure the controller is connected to the power supply</p>  <p>b) disconnect the leg cable plugs from the controller</p>  <p>c) unplug the power cord for <b>10 seconds</b></p> <p>d) reconnect the power cord to the network and check if it is connected to the controller</p>  <p>e) reconnect the leg cable plugs to the controller until you hear a "click" on the plug latch</p>  <p>f) calibrate the legs according to the solution no 2.</p>

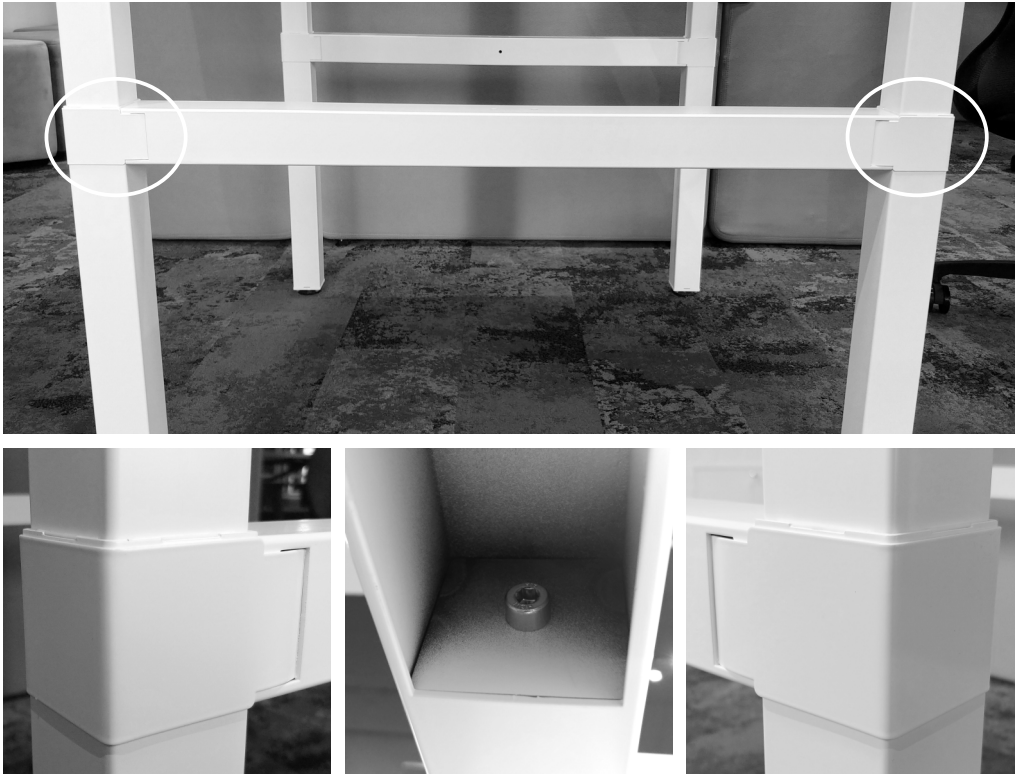
L.p.	ISSUE	POSSIBLE SOLUTION
4	<p>After pressing the "+" or "-" button, the desk starts moving, but automatically stops and reverses by 4cm, the message LOWER / UPPER ANTICOLLISION appears on the display</p>	<p>1. The anti-collision system has been activated - during movement the worktop has encountered an obstacle - REMOVE THE OBSTACLE</p> <p>2. The anti-collision system has been activated despite the fact that the worktop has not encountered any obstacle. MAKE SURE THAT:</p> <ul style="list-style-type: none"> <li>a) the desk has been at room temperature for at least 1 hour</li> <li>b) the entire desk is solidly bolted together without loose screws</li> <li>c) the control unit is well mounted - it does not move</li> <li>d) the power cable is attached to the desk structure via bracket, according to the manual, so that pulling it does not cause the controller to move</li> <li>e) the desk is levelled and not overloaded</li> <li>f) in bench-type desks - Make sure that the beam clamp connecting the legs is not screwed too tight (screwing the beam clamp too tight may cause deformation of the legs, preventing smooth movement of the internal columns)</li> </ul> <div style="text-align: center;">  </div> <p>g) finally calibrate according to the solution <b>no 3</b>.</p>
5	<p>After repeatedly changing the worktop position (in a short time) the desk stopped working</p>	<p>The controller has overheating protection, which prevents further operation. Wait 18 minutes for the controller and engines to cool down.</p> <p>In desks with the PRO control panel - the cooling time is shown on the display.</p>

If none of the presented solutions brought the expected result, please contact the distributor by sending a short video showing the reaction/lack of reaction of the desk to pressing the "+" and "-" buttons

If it is not possible to make a video, complete the following form with a description of the situation:

Suggested solutions to the problem have been checked according to the factory manuals, but the desk is still not working properly.	
Action:	Description of desk reaction
Pressing the "+" button	...
Pressing the "-" button	...

### Simplified calibration procedure

Check if the controller is connected to the power supply and the control panel and legs are connected to the controller.



Subsequently:

**STANDARD control panel:**









1. Press simultaneously and hold both buttons continuously for 4 seconds



2. After this action, the  button remains inactive
3. Subsequently using the  button, lower the desk down to the lowest position of both columns
4. After that action, the  button will be active



**PRO control panel:**



1. Press simultaneously and hold all 3 buttons (    ) continuously for 4 seconds
2. After this action, the  button remains inactive
3. Subsequently using the  button, lower the desk down to the lowest position of both columns
4. After that action, the  button will be active

## Sehr geehrter Kunde!

Wenn Sie bemerkt haben, dass Ihr Schreibtisch nicht richtig funktioniert, prüfen Sie bitte Folgendes:

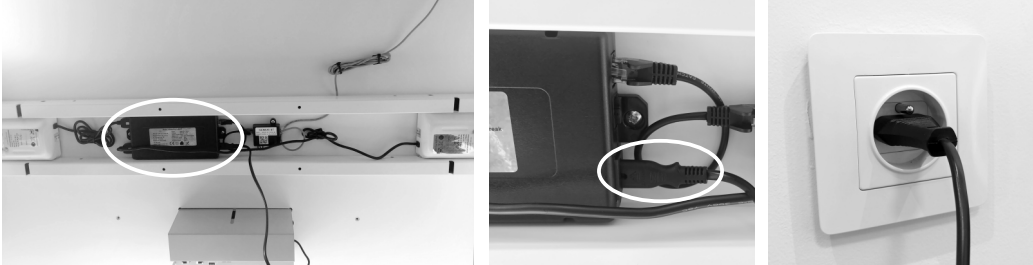
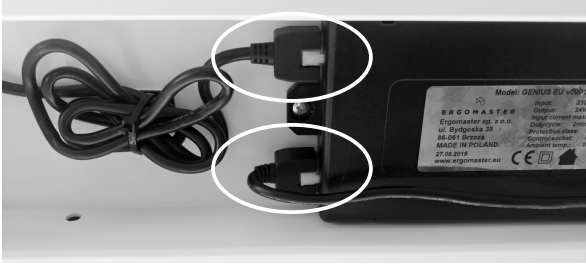
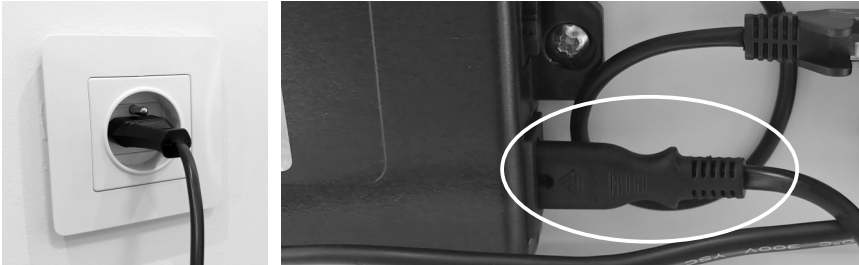
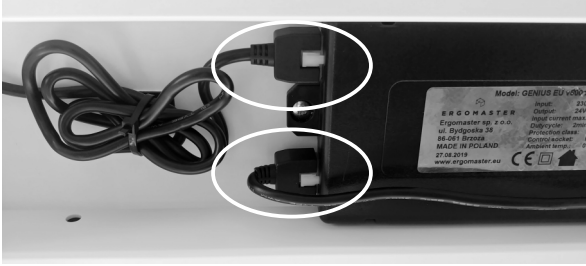
L.p.	PROBLEM	MÖGLICHE LÖSUNG
1	Schreibtisch reagiert auf die Tasten nicht	Überprüfen Sie den Anschluss des Netzkabels an Netzwerk und an Steuerung.
2	Die Taste  funktioniert nicht	Halten Sie die Taste  gedrückt, bis die Tischplatte in die niedrigste Position abgesenkt ist. Die Beine werden kalibriert und die Tischplattenverstellung wird in beide Richtungen wiederhergestellt.
3	Ein Bein funktioniert nicht mehr oder hat eine andere Höhe	<p>Der Kalibrierungsverlauf sollte erneut durchgeführt werden. Zu diesem Zweck:</p> <p>a) vergewissern Sie sich zuerst, dass die Steuerung an die Stromversorgung angeschlossen ist</p>  <p>b) schalten Sie die Kabelstecker der Beine von der Steuerung aus</p>  <p>c) schalten Sie das Netzkabel für <b>10 Sekunden</b> lang vom Netz aus</p> <p>d) schließen Sie das Netzkabel an das Stromnetz an und überprüfen Sie die Verbindung mit der Steuerung</p>  <p>e) schließen Sie die Kabelstecker der Beine von der Steuerung an, bis Sie das Klicken des Steckerhakens hören</p>  <p>f) kalibrieren Sie die Beine gemäß <b>Punkt 2</b>.</p>

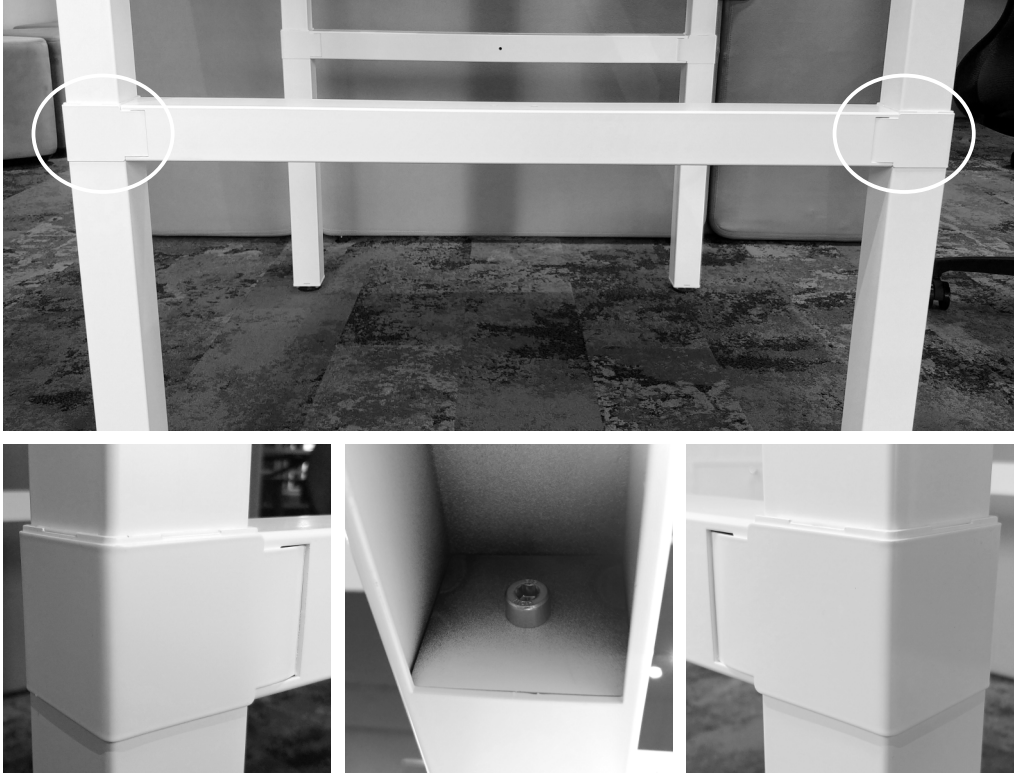
L.p.	PROBLEM	MÖGLICHE LÖSUNG
4	<p>Nach dem Drücken der Taste "+" oder "-" beginnt der Tisch sich zu bewegen, stoppt jedoch automatisch und rückt um 4 cm zurück. Auf dem Display zeigt sich die Meldung: LOWER/UPPER ANTICOLLISION</p>	<ol style="list-style-type: none"> <li>1. Das Antikollisionssystem wurde aktiviert - während der Bewegung ist die Arbeitsplatte auf ein Hindernis gestoßen - HINDERNIS ENTFERNEN</li> <li>2. Das Antikollisionssystem wurde aktiviert, obwohl die Arbeitsplatte auf kein Hindernis gestoßen ist. VERGEWISSERN SIE SICH, DASS: <ol style="list-style-type: none"> <li>a) sich der Schreibtisch mindestens eine Stunde bei Raumtemperatur befunden hat</li> <li>b) der ganze Schreibtisch richtig montiert wurde, gut verdreht ist, ohne dass sich die Schrauben lockern</li> <li>c) die Steuerung richtig befestigt wurde und sich nicht bewegt</li> <li>d) das Stromkabel mit einer Halterung befestigt an den Schreibtisch ist, (gemäß den Anweisungen), so dass das Ziehen des Kabels keine Bewegungen der Steuerung verursacht</li> <li>e) der Schreibtisch waagrecht ausgerichtet und nicht überlastet ist</li> <li>f) in Bench-Schreibtischen - vergewissern Sie sich, dass die Traversen, die die Beine verbinden, nicht zu stark verdreht sind (zu starkes Verdrehen kann zu einer Verformung der Beine führen und eine reibungslose Bewegung der inneren Säulen verhindern).</li> </ol> </li> </ol> <div style="text-align: center;">  </div> <p>g) Führen Sie eine Kalibrierung nach <b>Punkt 3.</b> durch.</p>
5	<p>Nachdem die Position der Tischplatte mehrmals (in kurzer Zeit) gewechselt wurde, funktioniert der Schreibtisch nicht mehr</p>	<p>Die Steuerung verfügt über einen Überhitzungsschutz, der weitere Arbeit verhindert. Warten Sie 18 Minuten, bis die Steuerung und die Motoren abkühlen. Bei Schreibtischen mit Pro-Steuerungspanel wird die Abkühlzeit auf dem Display angezeigt.</p>

Wenn keine der vorgestellten Lösungen das Problem gelöst hat,  
wenden Sie sich bitte an den Händler/Verkaufspartner,  
indem Sie einen kurzen Film senden, wo das Funktionieren / keine Reaktion für  
das Drücken der Tasten "+" und "-" dargestellt wurde.

Falls Sie keinen Film drehen können,  
senden Sie uns bitte die folgende Anmeldung mit der Problembeschreibung:

Lösungsvorschläge der Probleme wurden gemäß den Anweisungen des Herstellers  
getestet, der Schreibtisch funktioniert jedoch immer noch nicht ordnungsgemäß

Problem:	Beschreibung des Schreibtischverhaltens
Drücken "+"	...
Drücken "-"	...

### Vereinfachter Kalibrierungsverlauf

Prüfen Sie, ob die Steuerung an die Stromversorgung angeschlossen ist und das Bedienfeld und die  
Beine mit der Steuerung verbunden sind.

Dann:

**STANDARD-Steuerung:**



1. Halten Sie zwei Tasten gleichzeitig 4 Sekunden lang gedrückt



2. Nach diesem Vorgang bleibt die Taste **+** inaktiv
3. Mit der Taste **-** senken Sie den Schreibtisch auf die niedrigste Position beider Säulen
4. Nach diesem Vorgang ist die Taste **+** aktiv





**Panel sterujący PRO:**



1. Halten Sie drei Tasten gleichzeitig 4 Sekunden lang gedrückt: **S + -**
2. Nach diesem Vorgang bleibt die Taste **+** inaktiv
3. Mit der Taste **-** senken Sie den Schreibtisch auf die niedrigste Position beider Säulen
4. Nach diesem Vorgang ist die Taste **+** aktiv

## Cher client,

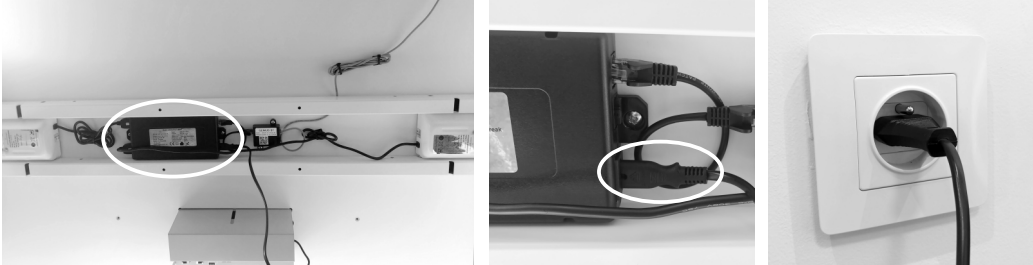
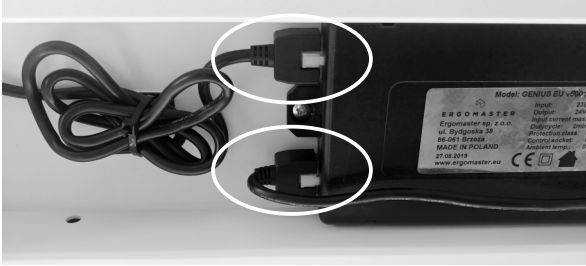
Si vous avez remarqué que votre bureau ne fonctionne pas correctement, veuillez vérifier les solutions suivantes

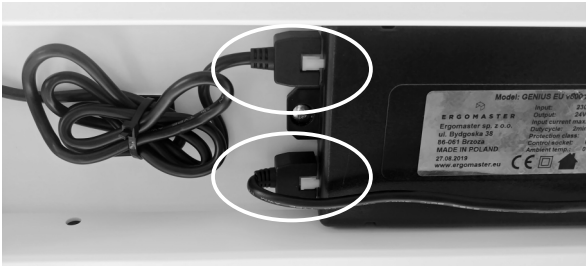
N°	PROBLEME	SOLUTION POSSIBLE
1	Le bureau ne répond pas lorsque l'on appuie sur les boutons	Vérifier que le câble d'alimentation soit bien connecté à une prise secteur en service, et la connexion du câble au panneau de contrôle.
2	Le bouton  enfoncé jusqu'à ce que le plan de travail soit abaissé à la position la plus basse - les piètements seront calibrées et la fonction de réglage du plan de travail sera restaurée dans les deux directions.	Maintenir le bouton  enfoncé jusqu'à ce que le plan de travail soit abaissé à la position la plus basse - les piètements seront calibrées et la fonction de réglage du panneau de contrôle sera restaurée dans les deux directions.
3	Un des pieds a cessé de fonctionner ou est à une hauteur différente	<p>Le processus d'étalonnage doit être effectué à nouveau. Pour ce faire :</p> <p>a) s'assurer que le panneau de contrôle est connecté à l'alimentation</p>  <p>b) débrancher les fiches de câble qui alimentent les pieds du panneau de contrôle</p>  <p>c) débrancher le cordon d'alimentation pendant <b>10 secondes</b></p> <p>d) reconnecter le cordon d'alimentation au secteur et vérifier s'il est connecté au panneau de contrôle</p>  <p>e) reconnecter les fiches de câble des piètements au panneau de contrôle, un "clic" se fait entendre</p>  <p>f) calibrer les piètements en suivant la solution <b>no 2</b>.</p>

N°	PROBLEME	SOLUTION POSSIBLE
4	<p>Après avoir appuyé sur le bouton « + » ou « - », le bureau commence à bouger, mais s'arrête et s'inverse automatiquement de 4 cm, le message LOWER / UPPER ANTICOLLISION apparaît sur l'écran</p>	<p>1. Le système anti-collision s'est activé - pendant le mouvement le plan de travail a rencontré un obstacle - ENLEVER L'OBSTACLE</p> <p>2. Le système anticollision a été activé malgré le fait que le plan de travail n'a rencontré aucun obstacle. ASSUREZ-VOUS QUE :</p> <ul style="list-style-type: none"> <li>a) le bureau est à température ambiante depuis au moins 1 heure</li> <li>b) l'ensemble du bureau est solidement boulonné et sans vis desserrées</li> <li>c) le panneau de contrôle est bien monté - il ne bouge pas</li> <li>d) le câble d'alimentation est fixé à la structure du bureau, comme indiqué dans le manuel de montage, de sorte que le mouvement ne le tire pas et provoque un déplacement du panneau de contrôle</li> <li>e) le bureau est de niveau et n'est pas surchargé</li> <li>f) dans le cas des bureaux de type bench - Assurez-vous que les pinces du barreau reliant les piètements ne soient pas vissées trop serrées (cela peut entraîner une déformation des piètements, et empêche le mouvement fluide des colonnes internes)</li> </ul> <div style="text-align: center;">   </div> <p>g) enfin calibrer selon la solution <b>no 3</b>.</p>
5	<p>Après avoir changé à plusieurs reprises la position du plan de travail (en peu de temps), le bureau a cessé de fonctionner</p>	<p>Le boîtier du panneau de contrôle est équipé d'une protection contre la surchauffe, stoppant la poursuite du fonctionnement. Attendre 18 minutes pour que le boîtier et les moteurs refroidissent. Pour les bureaux avec le panneau de commande PRO - le temps de refroidissement est affiché sur l'écran.</p>

Si aucune des solutions proposées n'a apporté de résultat, contacter le distributeur.

Envoyer une courte vidéo montrant la réaction ou le manque de réaction du bureau lors de l'utilisation des boutons « + » et « - »

S'il n'est pas possible de faire une vidéo,  
remplir le formulaire suivant avec une description de la situation :

Les solutions suggérées au problème ont été vérifiées selon les manuels d'usine, mais le bureau ne fonctionne toujours pas correctement.	
Action :	Description de la réaction du bureau
Appuyer sur le bouton « + »	...
Appuyer sur le bouton « - »	...

### Procédure d'étalonnage simplifiée

Vérifiez si le boîtier du panneau de contrôle est connecté à l'alimentation électrique et aux pieds du bureau.

Ensuite :

Panneau de contrôle STANDARD :



1. Appuyer simultanément et maintenir les deux boutons en continu pendant 4 secondes

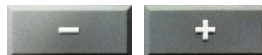

2. Après cette action, le bouton **+** reste inactif
3. Par la suite en utilisant le bouton **-**, régler le bureau à la position la plus basse des deux colonnes de piètement
4. Après cette action, le bouton **+** sera actif

Panneau de contrôle PRO :



1. Appuyez simultanément et maintenez les 3 boutons (**S** **+** **-**) en continu pendant 4 secondes
2. Après cette action, le bouton **+** reste inactif
3. Par la suite en utilisant le bouton **-** régler le bureau à la position la plus basse des deux colonnes de piètement
4. Après cette action, le bouton **+** sera actif